

NOTES:

- ① ARMORTEX® BULLET RESISTANT ARMOR
- ② UNFINISHED VENEER
- ③ 16 GA. PRIME PAINTED STEEL FRAME
- ④ PARTICLE BOARD CORE
- ⑤ CONTINUOUS GEAR HINGE (NOT SHOWN)
- ⑥ HARDWARE PREPERATION AS REQUIRED (NOT SHOWN)
- ⑦ GLAZING TAPE
- ⑧ BULLET RESISTANT GLAZING
- ⑨ NEOPRENE SETTING BLOCK
- ⑩ WOOD TRIM

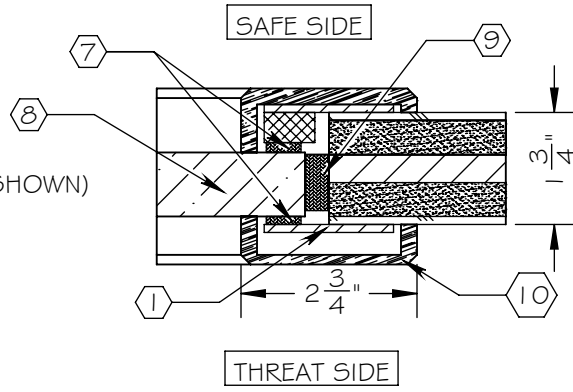

SECTION B-B  
SCALE 1 : 3

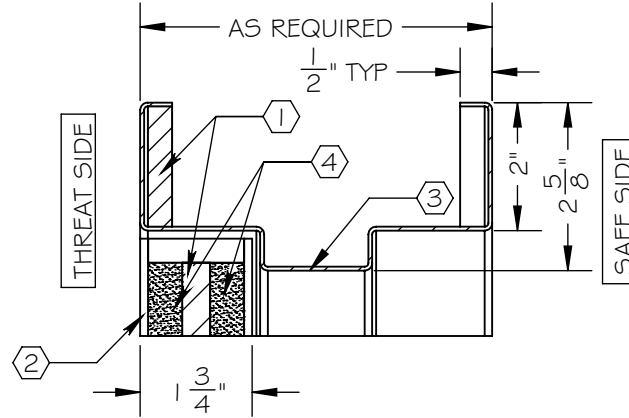

SECTION A-A  
SCALE 1 : 3

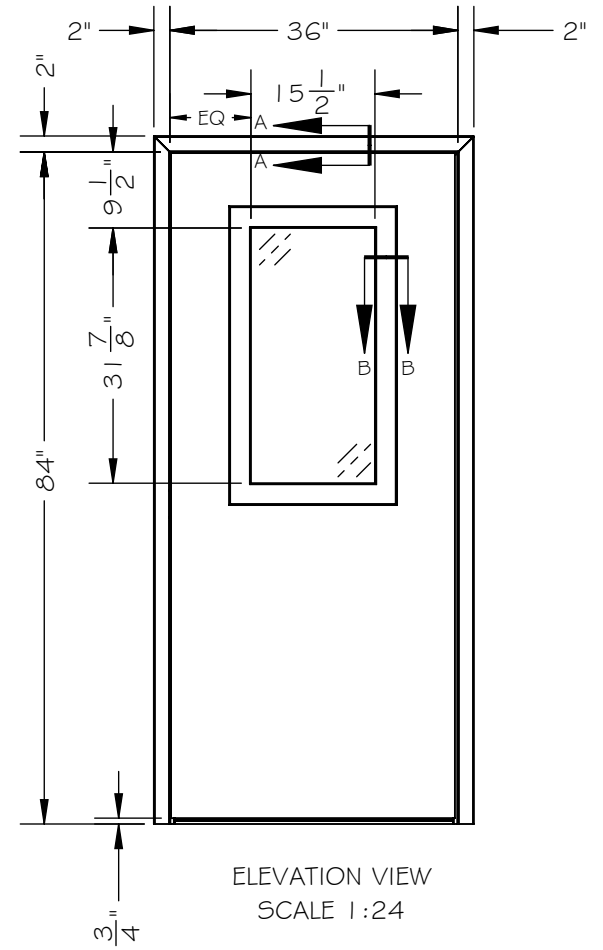

ELEVATION VIEW  
SCALE 1 : 24

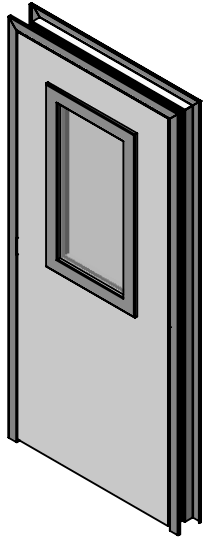

SCALE: AS NOTED	TITLE: WOOD HALF LITE DOOR	UNLESS OTHERWISE SPECIFIED: DIMENSIONS ARE IN INCHES TOLERANCES: FRACTIONAL: ±1/16" ANGULAR: ±1° TWO PLACE DECIMAL ±.01 THREE PLACE DECIMAL ±.005
DATE: 06-01-2015	MODEL: DR-WD-HL-DB	
DRAWN BY: M. FREEMAN	SHEET NUMBER: 1 OF 1	
		<p><b>ARMORTEX®</b>          BULLET • BLAST • FORCED ENTRY - PROTECTION PRODUCTS          5926 CORRIDOR PKWY SCHERTZ, TX 78154          TEL: 210-661-8306 800-880-8306 FAX: 210-661-8308          www.armortex.com</p>