

NOTES:

- ① GLAZING AS REQUIRED PER BALLISTIC OR FORCED ENTRY PROTECTION STANDARD
- ② THIS DIMENSION VARIES AS GLAZING VARIES
- ③ 12 GA. STAINLESS STEEL FACE PLATE
- ④ 1/4" THICK BALLISTIC STEEL PIVOT PLATE
- ⑤ 1/4" THICK BALLISTIC STEEL PLATE
- ⑥ PIVOT (INSTALL AT TOP DEAD CENTER)
- ⑦ REMOVABLE LOCKING PIN
- ⑧ STOP
- ⑨ KNOB

INSTALLATION INSTRUCTIONS

- 1- REMOVE RING "A" FROM REMAINDER OF ASSEMBLY BY REMOVING THREE 1/4" STAINLESS STEEL SCREWS.
- 2- TRIM CONCEALED SURFACE OF RING "A" WITH TREMCO 440 OR EQUAL, 1/16" THICK.
- 3- PLACE RING "A" CENTERED OVER OPENING WITH PIVOT SCREW POSITIONED AT TOP DEAD CENTER.
- 4- TRIM CONCEALED SIDE OF RING "B" WITH TREMCO AND PLACE CENTERED OVER HOLE WHERE HOLES LINE UP WITH WELD NUTS ON INSIDE OF RING "A".
- 5- INSTALL PIVOT PLATE OVER SPACER AT TOP DEAD CENTER.
- 6- INSTALL INTERIOR FACEPLATE AND SECURE WITH THREE 1/4" SCREWS.

CAUTION:

DO NOT OVERTIGHTEN AND NEVER ATTEMPT TO INSTALL ON AN AIR GAP GLAZING PRODUCT.

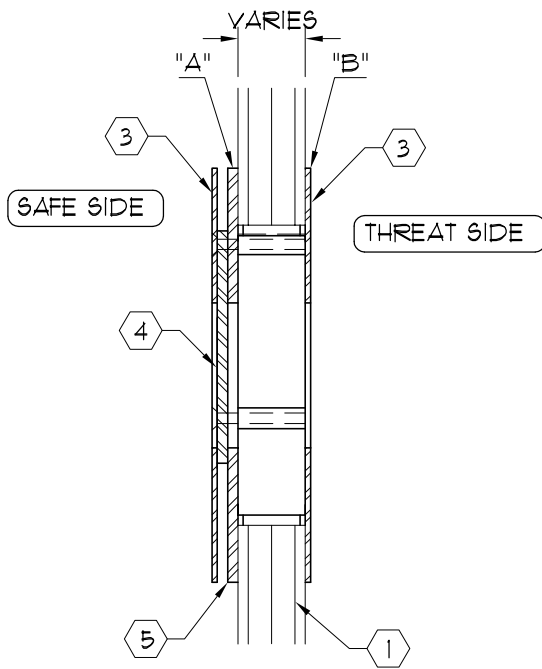

SECTION A-A

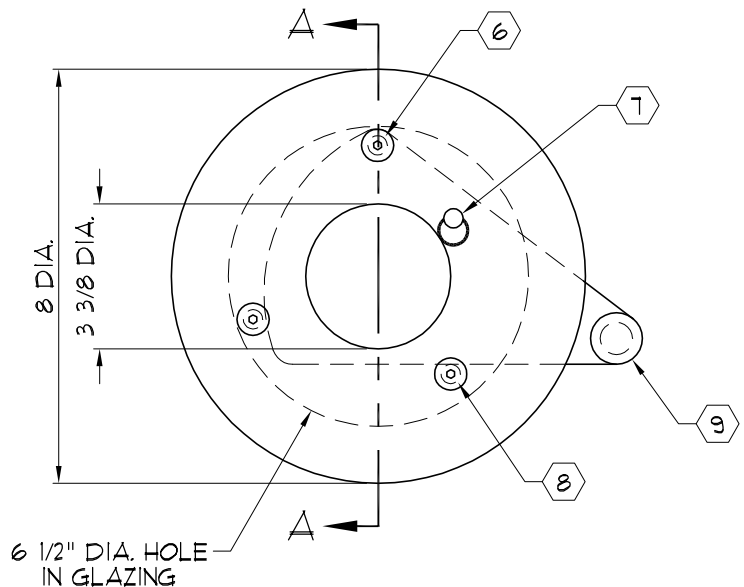

ELEVATION
(_ - REQUIRED)

C:\ARMORTEX MASTERS - 2007\GUNPORT\G1018001.DWG.DWG 02/20/07 @ 09:47 User: aperez

REVISIONS			ARMORTEX ® BULLET / BLAST RESISTANT PRODUCTS		BALLISTIC LEVEL 4	
No.	DESCRIPTION	DATE	5926 CORRIDOR PKWY SCHERTZ, TX 78154		DRN.BY:	DATE:
			TEL: 210-661-8306 800-880-8306 FAX: 210-661-8308		A. Perez	02-16-07
			TITLE:	PROJECT NAME:		
			ARMORTEX® BULLET RESISTANT PIVOT GUNPORT SSGP-8			
			UNLESS OTHERWISE SPECIFIED ALL DIMENSIONS ARE IN INCHES	SCALE	PROJECT No.	DRAWING No.
				NONE		G1018001
					SHEET	1 OF 1